

h400, h630 Plug-in

- (FR) Disjoncteurs boîtiers moulés 250 - 400 - 630 A
- (EN) Moulded case circuit breakers 250 - 400 - 630 A
- (DE) Leistungsschalter 250 - 400 - 630 A
- (IT) int. scatola 250 - 400 - 630 A
- (ES) Interruptores automáticos 250 - 400 - 630 A
- (NL) Vermogens automaat 250 - 400 - 630 A
- (PT) Disjuntores gerais 250 - 400 - 630 A
- (NO) Effektbryter 250 - 400 - 630 A
- (EL) Αυτόματοι διακόπτες ισχύος 250 - 400 - 630 A
- (PL) Wyłączniki kompaktowe 250 - 400 - 630 A
- (RU) Автоматические выключатели в литых корпусах < 250 - 400 - 630 A
- (ZH) 塑壳断路器 250 - 400 - 630 A

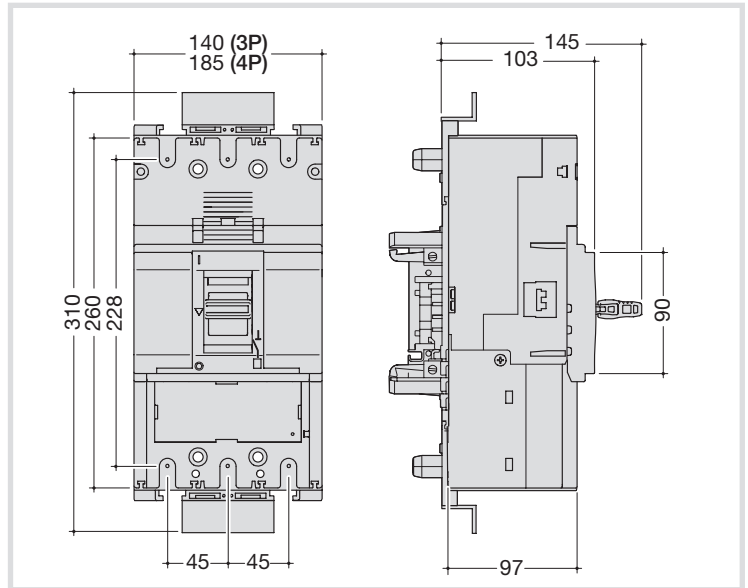
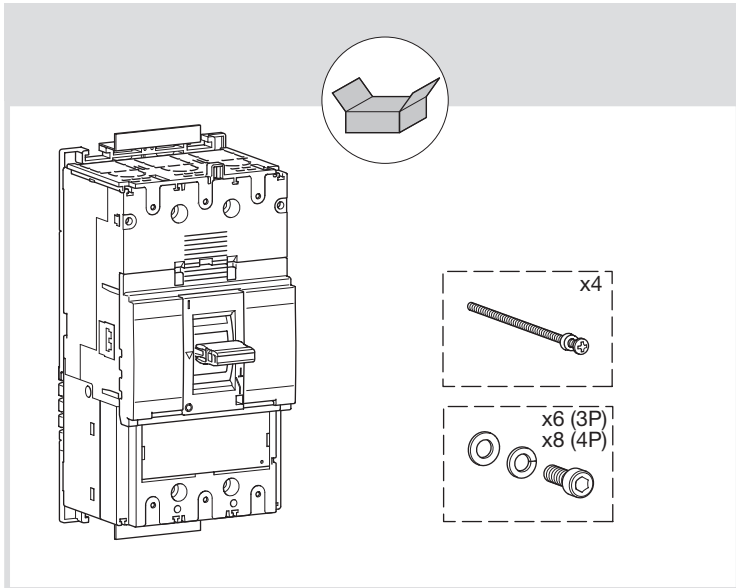

⚠ Open the MCCB before mounting or removing

	220/240 V AC	380/415 V AC	660/690 V AC
h630 LSI Icu (kA)	100	70	20
HED Ics (kA)	85	50	15

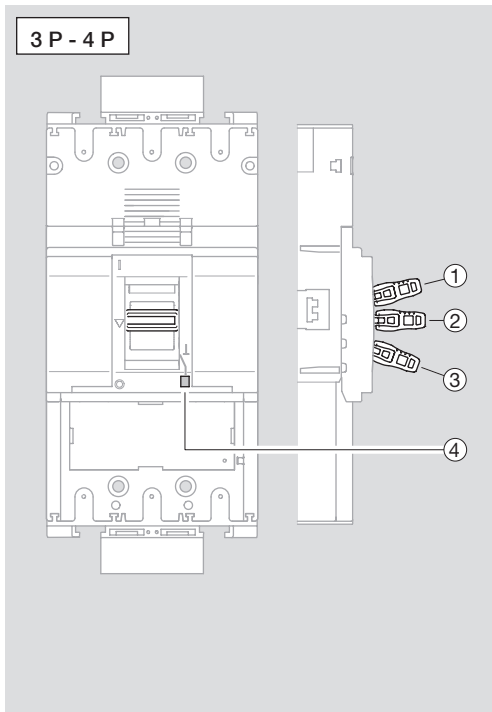

- 3 P - 4 P**
- | | | |
|--|--|---|
| <p>Indicateur de position de la manette:</p> <ul style="list-style-type: none"> ① rouge = ON, ② noir = Déclenché, ③ vert = OFF (Reset). ④ Bouton de déclenchement <p>Handle position indicator :</p> <ul style="list-style-type: none"> ① red = ON, ② black = Trip, ③ green = OFF (Reset). ④ Button, Push-to-Trip <p>Position des Schalthebels :</p> <ul style="list-style-type: none"> ① rot = EIN, ② schwarz = ausgelöst, ③ grün = AUS (Reset). ④ Prüftaste, zum auslösen drücken <p>Indicatore di posizione della leva di manovra :</p> <ul style="list-style-type: none"> ① rosso = ON, ② nero = Scanciato, ③ verde = OFF (Reset). ④ Pulsante di sgancio <p>Visualización de la posición :</p> <ul style="list-style-type: none"> ① rojo = ON, ② negro = Disparo, ③ verde = OFF (Reset). ④ Pulsador de disparo | <p>Hendelstand-indicator :</p> <ul style="list-style-type: none"> ① rood = ON, ② zwart = Uitgeschakeld, ③ groen = OFF (Reset). ④ Uitschakelknop <p>Indicador de posição do punho :</p> <ul style="list-style-type: none"> ① encarnado = ON, ② preto = Disparo, ③ verde = OFF (Reset). ④ Botão de disparo <p>Bryterknappens posisjon indikerer :</p> <ul style="list-style-type: none"> ① rød = PÅ, ② sort = Utløst, ③ grønn = AV (Reset). ④ Utløserknapp <p>Οπτική ένδειξη της κατάστασης του διακόπτη :</p> <ul style="list-style-type: none"> ① κόκκινο = ON, ② μαύρος = πτώση διακόπτη ισχύος, ③ πράσινο = OFF (Reset). ④ Πλήκτρο διακοπής <p>Pozycje dźwigni:</p> <ul style="list-style-type: none"> ① czerwony = ON ② czarny = Trip ③ zielony = OFF (Reset) ④ Przycisk - Wcisnij aby wyzwolić | <p>Индикатор положения раб. органа:</p> <ul style="list-style-type: none"> ① красный = ВКЛ, ② черный = расцеплен ③ зелёный = Выкл(Готов) ④ Кнопка, Нажать для расцепления <p>手柄位置指示:</p> <ul style="list-style-type: none"> ① 红 = ON (释能), ② 黑色 = trip (储能) ③ 绿 = OFF/Reset ④ 按钮 按压脱扣 |
|--|--|---|

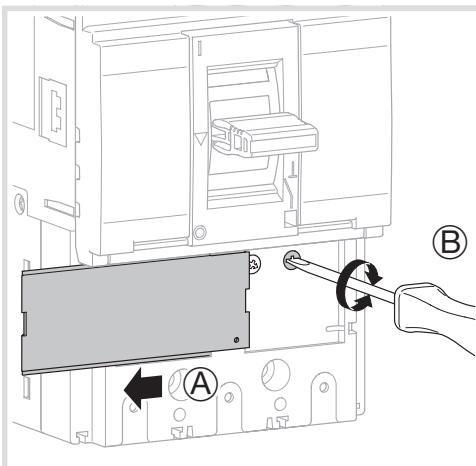

- Réglages
- Trip unit settings
- Einsteller
- Regolazioni
- Regulaciones
- Instellingen
- Regulações
- Innstillinger
- Ρυθμίσεις
- Nastawa wyzwoleń
- Уставки блока расцепителя
- 脱扣单元设定

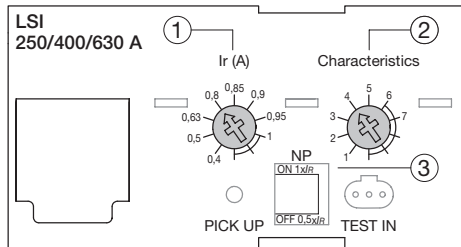

- ③
- Protection du neutre
 - Neutral protection
 - Einsteller für Neutralleiterschutz
 - Protezione del neutro
 - Protección de neutro
 - Beveiliging van de nulleider
 - Protecção do neutro
 - Vern i nulleider
 - Προστασία ουδέτερου
 - Ochrona bieguny neutralnego
 - Уставки блока расцепителя
 - 中性极保护

LSI	In A											
	250 A / 400 A				250 A / 400 A							
	Long Time Delay		Short Time Delay		Inst		Long Time Delay		Short Time Delay		Inst	
Ir (x In)	tr (s)	tsd (xlr)	li (xlr)	Ir (x In)	tr (s)	tsd (xlr)	li (xlr)	Ir (x In)	tr (s)	tsd (xlr)	li (xlr)	
Ir (x In)	0,4	ok			ok							
	0,5	ok			ok							
	0,63	ok			ok							
	0,8	ok			ok							
	0,85	/			ok							
	0,9	ok			ok							
	0,95	ok			ok							
1	ok			ok								
Characteristics	1		11 s at 2 xlr	2,5	0,1	14 (Max 13 x In)		11 s at 2 xlr	2,5	0,1	14 (Max 10 x In)	
	2		21 s at 2 xlr	5				21 s at 2 xlr	5			
	3		5 s at 6 xlr	10				5 s at 6 xlr	8			
	4		10 s at 6 xlr				10 s at 6 xlr					
	5		19 s at 6 xlr				16 s at 6 xlr					
	6		29 s at 6 xlr									
	7											

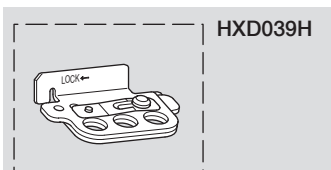
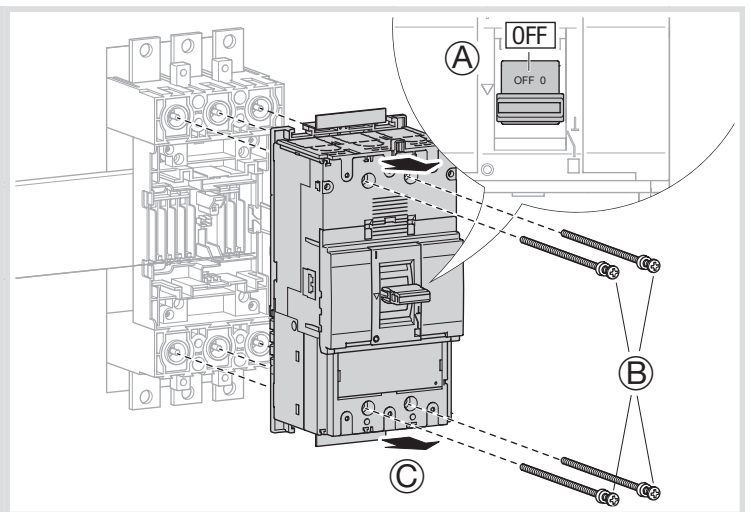
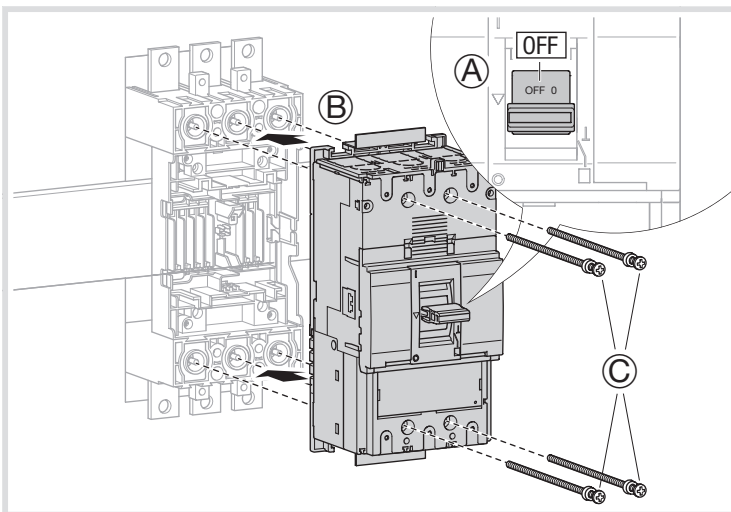
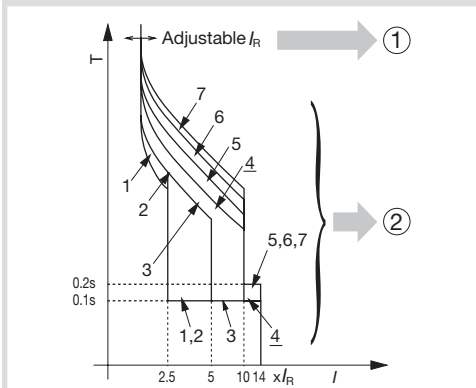

- Kit de verrouillage manette
- Padlockable Handle Lock Hasp
- Knebelverriegelung
- Blocco leva
- Pieza bloqueo mando
- Vergrendelkit voor hendel
- Kit de bloqueamento do punho
- Hengelåssperre
- Εξάρτημα κλειδώματος
- Blokada dźwigni
- Система замка рукоятки
- 可加挂锁的手柄锁

